

3. Central locking additional installation

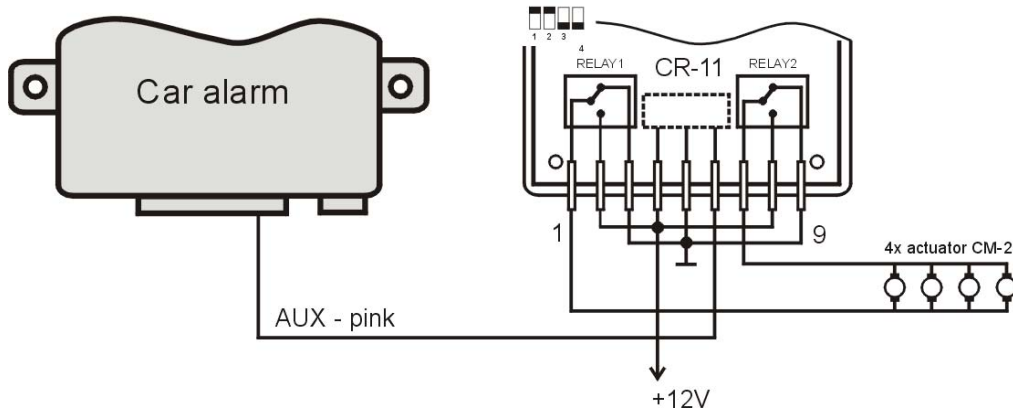

Select mode number 4 on the CR-11A module. Select a duration of 0.5 sec. in car alarm setting mode. A setting other than 0.5s will, in this case, cause damage to the actuators!

4. Arming indication by turn lights (flashers)

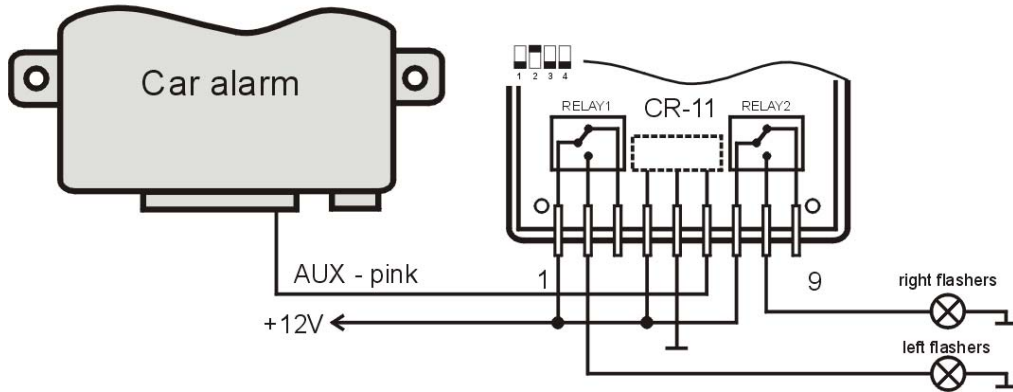

Select mode number 3 on the CR-11A module.



Pod Skalkou 33
466 01 Jablonec nad Nisou
Czech Republic
Tel.: 483 559 911
fax: 483 559 993
Internet: www.jablotron.com

The CR-11A expander module - instructions

The CR-11A is an expander output module which provides additional functions for CA-180x, CA-32x, and CA-1x Jablotron car alarms. The module can be used for central-locking control, immobilization, an additional siren, electric window remote control, or for controlling appliances via SMS. It has two built-in relays, each with a 15 Amp switch-over contact. The functions of the relays are selectable by the DIP switches inside each CR-11A. The module receives data from the car alarm via a single wire (digital communication). The older CR-11 module can be combined with the CR-11A. Up to four CR-11/CR-11A units can be connected to each of the above mentioned Jablotron car alarms.

Specifications

Voltage	12V DC (10-16V DC)
Consumption	stand by 5 mA
	max. 300 mA (both relays on)
Relay output contacts (each)	continuous 15 A
	max 20 A (30 seconds)
Working temperature	-40 to +85 °C
The CR-11 complies with IEC 839-10-1 and UN ECE No. 97	



This product complies with the essential requirements of EU directive 89/336/EC (EMC – protection) concerning electromagnetic compatibility when used for its intended purpose. The original of the conformity assessment can be found on www.jablotron.com, Technical Support section.



Note: Although this product does not contain any harmful materials, we suggest you return the product to the dealer or directly to the producer after usage.

Installation

Professional installation of the CR-11A is highly recommended. The module should be installed in the passenger compartment of the car. If you drill any holes in the car, be sure to check the location of the intended holes before drilling, to prevent damage to the car.

Disconnect the car battery before starting installation. Nobody should be inside a car equipped with airbags while the battery is being connected or disconnected. Refer to the car owners' manual before disconnecting the battery.

WIRING - route new wires with the pre-existing electrical harness of the car. Check each connection made to ensure that it is secure and properly insulated. Only use a proper crimping tool to make connections. If you use more than one CR-11A unit with a car alarm, connect all CR-11A data inputs (LINE) in parallel.





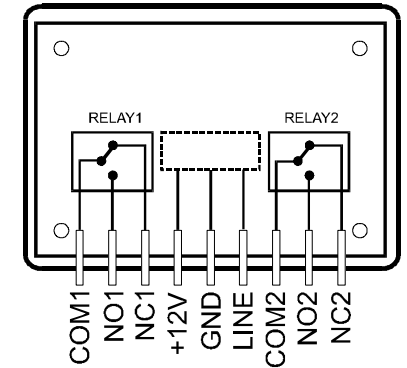

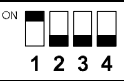

Signals on the CR-11A connector

- COM1 - common contact of relay 1
- NO1 - normally open contact of relay 1
- NC1 - normally closed contact of relay 1
- +12V - positive voltage from the car battery
- GND - ground
- LINE - data from the car alarm (AUX output)
- COM2 - common contact of relay 2
- NO2 - normally open contact of relay 2
- NC2 - normally closed contact of relay 2



Setting the CR-11A relay functions

Functions of the CR-11A relays can be selected inside the unit with DIP switches marked 1 - 4. Available options are described in the following table. Particular functions correspond to functions of the car alarm (see car alarm manual).

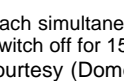
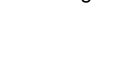
mode no.	DIP switch settings	Function of relay no. 1	Function of relay no. 2
1		1 sec. pulse after simultaneous pressing of A&B buttons on the remote control, when car alarm is armed	1 sec. pulse after simultaneous pressing of A&B buttons on the remote control, when car alarm is disarmed
2		relay will change status after simultaneous pressing of A&B on RC, when car alarm is armed /*	relay will change status after simultaneous pressing of A&B, on RC, when car alarm is disarmed /*
3		left flasher output signals (arming, disarming, alarm)	right flasher output signals (arming, disarming, alarm)
4		lock (pulse duration selectable in the car alarm setting mode)	unlock (pulse duration selectable in the car alarm setting mode)
5		immobilization (relay switches ON when car alarm is disarmed and the ignition key is ON)	alarm (relay switched ON during alarm condition)
6		immobilization (relay switches ON when car alarm is disarmed and the ignition key is ON)	arming signals (1 pulse = arming, 2 pulses = disarming)
7		courtesy (Dome) light control (relay follows door switches + 1 minute) /***	arming signals (1 pulse = arming, 2 pulses = disarming)
8		immobilization (relay switches ON when car alarm is disarmed and the ignition key is ON)	courtesy (Dome) light control (relay follows door switches + 1 minute) /***
9		double locking impulse – during arming relay will be switched ON for 0.3s, then switched OFF for 1s and switched ON for 0.3s again	double unlocking impulse – during disarming relay will be switched ON for 0.3s, then switched OFF for 1s and switched ON for 0.3s again
10		Second locking impulse – 1s after preset locking car alarm impulse, relay will be switched ON for 0.5s	Second unlocking impulse – 1s after preset unlocking car alarm impulse, relay will be switched ON for 0.5s
11		controlling of relay via SMS – only for CA-180x, see CA-180x manual for more details	controlling of relay via SMS – only for CA-180x, see CA-180x manual for more details

/* with each simultaneous press of the A&B buttons, the relay will toggle status (on - off - on ...). The relay will also switch off for 15 minutes or after arming or disarming

/** the courtesy (Dome) light is on while a door is open (max. 15 minutes) and it will remain on until you switch on the ignition key (max. 1 minute)

Examples of use

1. Trunk (boot) release by simultaneous pressing of A&B buttons on the remote control

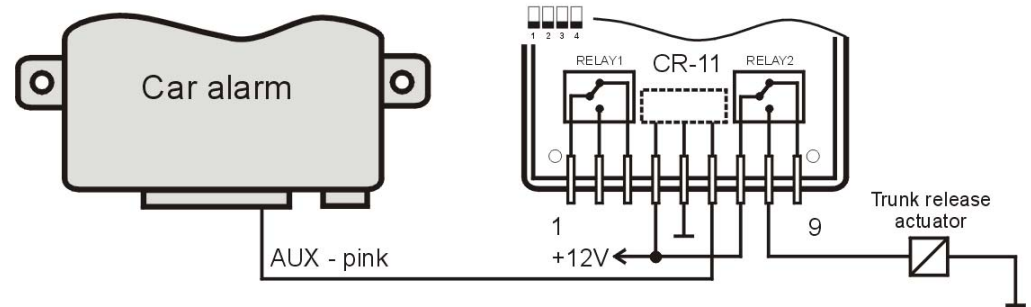

Select mode no. 1 on the CR-11A module and disable the Panic alarm in the car alarm settings (if this feature is supported). Opening the trunk (boot) by remote control is only possible when the car alarm is disarmed.

2. Additional immobilization and an additional siren

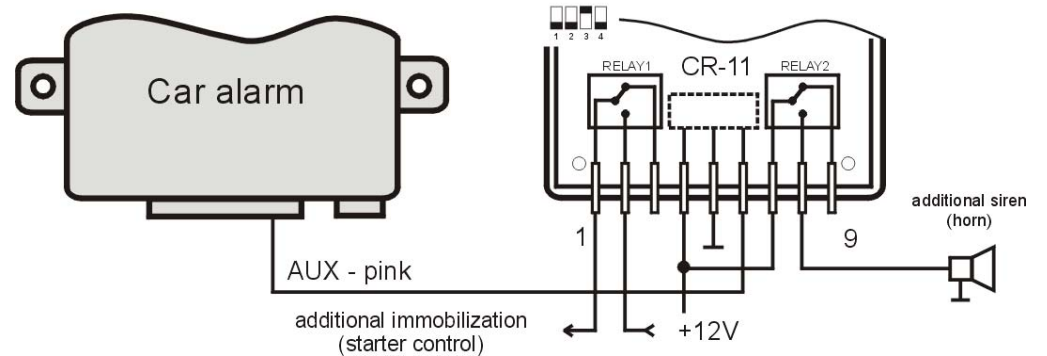

Select mode number 5 on the CR-11A module. The additional immobilization provides a higher security level, because it is impossible to bypass it even when somebody is tampering directly with the wire harness of the car alarm unit (the CR-11A is waiting for digital data from the car alarm). The additional siren sounds during the alarm period (the car horn can also be used as an additional siren).