

JA-80W wireless combined PIR + MW detector

The JA-80W is a component of Jablotron's Oasis alarm system. It is designed to detect human body movement inside buildings. A high immunity to false alarms is reached thanks to the combination of PIR and microwave (MW) detection. The PIR part, if triggered, starts the MW detection to confirm PIR activation. Only then is the triggering transmitted.

Installation

Installation shall only be undertaken by technicians holding a certificate issued by an authorized distributor. There should be no obstacles blocking the detector's "view" of the protected area. Keep the detector away from metal objects which could interfere with radio communication and the MW field.

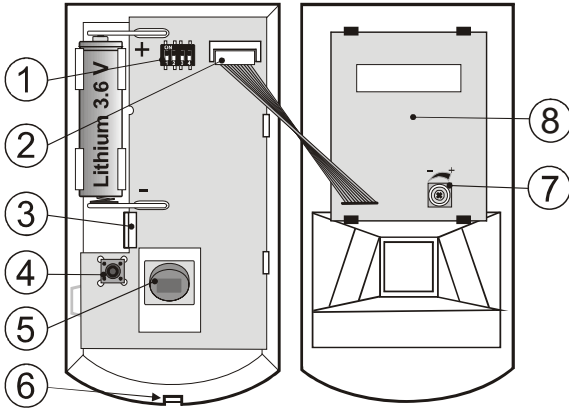

Description: 1. DIP-switch; 2. MW part connector; 3. PCB tab; 4. tamper-switch; 5. PIR sensor; 6. front cover tab; 7. MW sensitivity setting; 8. MW detector

- Open the detector cover by pressing the tab (6) and remove the PCB which is held by an internal tab (3). Avoid touching the internal PIR element or damaging the antenna.
- Punch screw holes through the rear plastic cover according to the installation point, either for a corner or for a flat wall. At least one screw should penetrate the tamper-sensitive section.
- Screw the rear cover to the wall, about 2.5 meters above the floor (vertically, with the tab down).
- Return the PCB to its original place till the tab (3) clicks.
- Leave the battery disconnected and the cover open and then follow the control panel or receiver manual. The basics of enrollment are:
 - Enter enrollment mode on the control panel by keying in "1" in Service mode.
 - Install a battery into the detector to activate enrollment.
 - Exit enrollment mode by pressing "#"
- Close the detector cover till the tab clicks. The supplied screw can secure the tab.
- After installing a battery into the detector, allow three minutes for stabilization. During this period the LED is continuously lit.

Notes:

To enroll a detector after having already connected a battery, first disconnect the battery, and press and release the tamper switch to discharge any remaining charge to get the device ready for enrollment.

The detector can also be enrolled by entering the serial number – the last eight numbers of the barcode, which is placed inside the detector.

To follow the EN 50131-2-4 the tab must be secured by the supplied screw.

DIP switch Setting

Switch no.1: DEL / INS: OFF (DEL) provides entrance & exit delays for detectors installed in a building entrance route. The **ON** (INS) allows the detector to instantly trigger alarm activation if the control panel is armed.

DIP switch no.1 only has an effect if the detector has a natural reaction assigned to it in the OASIS control panel. It also has no effect when used with a UC-8x or AC-8x receiver.

Switch no.2: PIR NORM / HIGH: selection of immunity to false alarms. The **OFF** (NORM) position combines very good immunity with fast sensor reactions. The **ON** (HIGH) position gives increased immunity with a slower reaction time and is only used for problematic installations.

Switch no.3: MW NORM / HIGH sets the time period after PIR detection in which the MW detection is active. The position **OFF** – 1 s, **ON** – 2 s

Switch no.4: MW NORM / TEST. The position **OFF** is for the standard function of the detector. The MW detection is triggered by the PIR detection part for one or two seconds according to switch no.3. The position **ON** - MW detection works continuously for testing purposes (walk test).

Testing the detector

15 minutes after closing the detector cover, the LED indicators show detector activation. A short flash of the red light indicates PIR detection and a long flash (2 sec) indicates MW confirmation of the movement.

For the proper functioning of the detector, it is essential to set the MW detection field according to the place which should be monitored. For setting up, switch the fourth DIP switch to the TEST position. Sensitivity (monitoring range) can be adjusted by a potentiometer on the MW detection part located inside the front cover of the detector. Turning clockwise increases the sensitivity (range). Avoid selecting too high a sensitivity as the detection can cover e.g. nearby rooms. Generally the MW detection field should be the same as the PIR detection one. After setting up, switch the DIP switch back to NORM position.

To save battery energy, the PIR detector switches to battery-save mode 15 minutes after the cover is closed. During battery-save mode the PIR sensor still always watches out for movement. The first movement detected and consecutively confirmed by the MW part is then signaled to the control panel instantly, and for the next 5 minutes the PIR sensor ignores any further movement. After these 5 minutes, the PIR sensor then returns to watching out for movement until re-triggered.

Battery replacement

The detector regularly checks its battery conditions. If battery voltage is too low, then the report is sent to the control panel to inform the user or installer. The detector continues to work and each detected movement is confirmed by a brief LED flash. The battery should be replaced within two weeks by a qualified technician in SERVICE mode.

After battery replacement, test the functioning of the detector. Expired batteries should not be thrown into the garbage, but disposed of according to local regulations.

Removing the detector from the system

If a detector is removed, the control panel reports the removal. The detector has to be deleted from its address in the control panel before intentional removal.

Detection characteristics

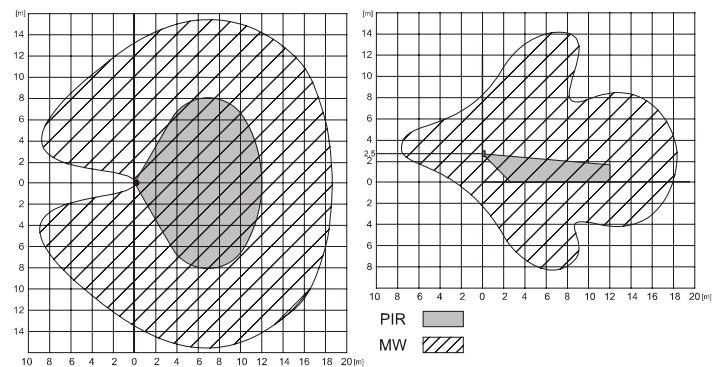

Technical parameters

Power supply:	Lithium battery type LS(T)14500 (3.6V / 2.4 Ah AA)
Typical battery lifetime:	approx. 2 years (DIP switch 3: NORM)
Communication band:	868 MHz, Oasis Protocol
Communication range:	approx. 300m (open area)
Recommended installation height:	2.0 to 2.5 m above floor level
PIR detection angle/detection range:	110° / 12 m (with basic lens)
MW detection range / frequency:	0.5 to 20 m / 9.35 GHz
Operational environment according to EN 50131-1	II, indoor general
Operational temperature range:	-10 to +40 °C
EN 50131-1, EN 50131-2-4, EN 50131-5-3 classification:	grade 2
Dimensions, weight:	110 x 60 x 55 mm, 140 g
Complies with:	ETSI EN 300220, ETSI EN 300 440-1, EN 50130-4, EN 55022, EN 60950-1
Can be operated according to:	ERC REC 70-03
Operation requires notification national telecommunication offices of:	Finland, France, Italy, Serbia and Montenegro, Spain, Sweden, UK



JABLOTRON ALARMS a.s. hereby declares that the JA-80W is in compliance with the essential requirements and other relevant provisions of Directive 99/5/EC. The original of the conformity assessment can be found at www.jablotron.com, Technical Support section

Note: Although this product does not contain any harmful materials we suggest you return the product to the dealer or directly to the producer after use.

JABLOTRON
CREATING ALARMS

JABLOTRON ALARMS a.s.
Pod Skalkou 4567/33
46601 Jablonec nad Nisou
Czech Republic
Tel.: +420 483 559 911
Fax: +420 483 559 993
Internet: www.jablotron.com